



CRITICAL COMPONENTS
GROUP

CTI-Cryogenics® 9600 Compressor

VACUUM PRODUCTS

Benefits

- Long-term reliability, through efficient modular system design and high-reliability components
- Ease of use, with three year maintenance-free operation between adsorber changes
- Supports remote controls for easy operation in remote-compressor installations
- Fast installation anywhere in the world, with global power compatibility, easy handling and hookup, and self-setting coldhead power control
- Extremely high capacity and efficient design for improved pump performance and fast regenerations
- Single and multiple pump capability
- Full compatibility with new and existing CTI-Cryogenics pumping systems
- Backed by GUTS® (Guaranteed Uptime Support)

Designed expressly for long usable life, high reliability, and easy use, the 9600 compressor provides outstanding performance with all Cryo-Torr Cryopumps, On-Board Cryopumps, On-Board Waterpumps, and On-Board TurboPlus Vacuum Pumps. It supports both single- and grouped-pump configurations, and it is compatible with new and existing CTI-Cryogenics pumping installations worldwide.

Designed for reliability and long usable life.

The 9600's design is simple and efficient, and its components and materials have been selected and tested for high reliability to support long usable compressor life.

Easy to set up and use.

The 9600 has been designed for fast unpacking, fast setup, and ease of use. It is a lightweight design, with large casters for easy handling, and its power, helium, and water hookups are all easily accessible for fast installation. The 9600 requires no maintenance beyond a recommended adsorber change once every three years. Circuit protection is provided by a single row of breakers which are easily accessible at the rear panel. The adsorber is easy to reach with the simple removal of a single side panel, and is designed for instant removal and replacement. Remote controls are supported, giving you the flexibility of remote compressor location.



CTI-Cryogenics® 9600 Compressor

9600 Compressor Specifications

Dimensions	26.54" h x 19.52" w x 21.50" d (674mm h x 496mm w x 546 mm d)
Weight	
Low-Voltage Model	250 lbs. (114kg)
High-Voltage Model	265 lbs. (120kg)
Operating Voltage (3-phase, 50 Hz or 60Hz)	
Low-Voltage Model	180-253 VAC
High-Voltage Model	360-506 VAC
Input power	5.5KW
Cooling water	2.75 GPM

When ordering, please specify single or multiple pump operation, and specify whether the compressor will power Cryo-Torr or On-Board pumps.

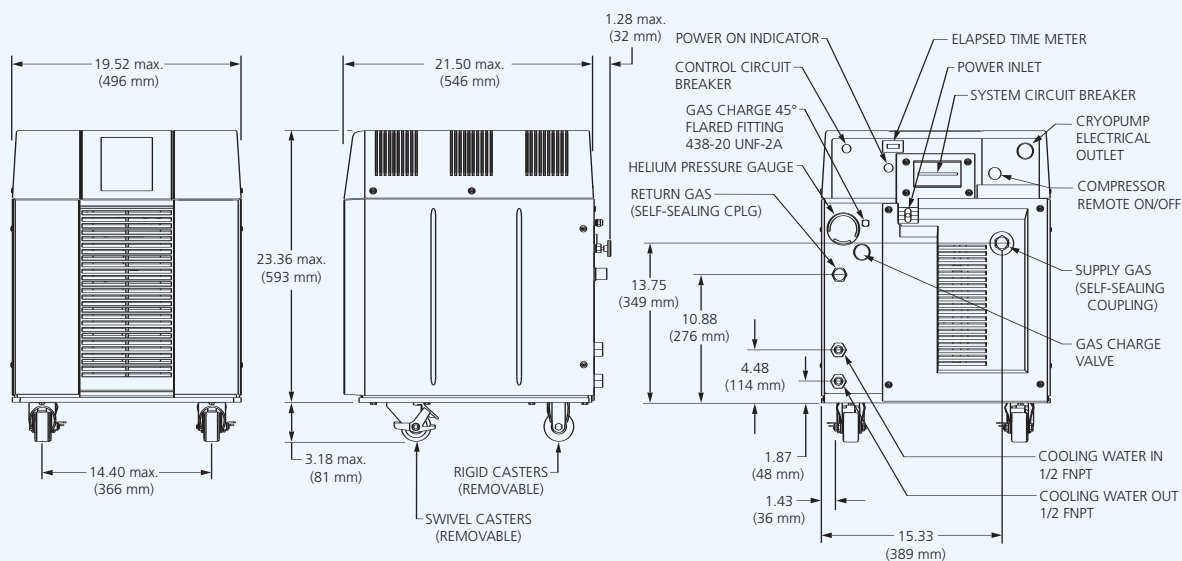

Global Power Compatibility

The 9600 features global power compatibility, with both low-and high voltage models available. Each model operates on both 50 Hz and 60 Hz power, and the allowable voltage range for each is substantial. The cryopump power supply automatically sets coldhead voltages so manual settings of power taps is not needed. Instead, cold head voltages are automatically controlled for reliable performance throughout the entire specified range of compressor supply voltage.

Backed by GUTS®

All CTI-Cryogenics products are backed by the GUTS (Guaranteed Up-Time Support) rapid response network, our comprehensive customer support program. When you call the GUTS service center, you are guaranteed immediate, competent response and action by a vacuum expert from our worldwide technical support staff. We're at work for you 24 hours a day, 365 days a year. In the U.S., dial 1-800-FOR-GUTS (800-367-4887).

For more information, please contact your local Brooks Automation sales representative or visit www.brooks.com.

